

Murrelektronik GmbH
Falkenstraße 3
71570 Oppenweiler
GERMANY

Phone +49 7191 47-0
Fax +49 7191 47-491000
info@murrelektronik.com

Document	Version
Product data	1.1
Art.-No.	Product designation
9000-41014-0400068	Mico67-4.4-CL2-A

Electronic circuit protection:

- IP67 for all connections,
- Easy installation directly on RobotUnits, aluminum profiles (ITEM, and 80/20)
- Plug-and-play integration,
- 4 x M12 ports, NEC Class 2 outputs, additionally secured with 4 A fuse,
- Device reset by disconnecting the supply cable (M12, L-coded, 4-pin).



Planning information, background information and accessories can be found at:
shop.murrelektronik.com

1 Device structure

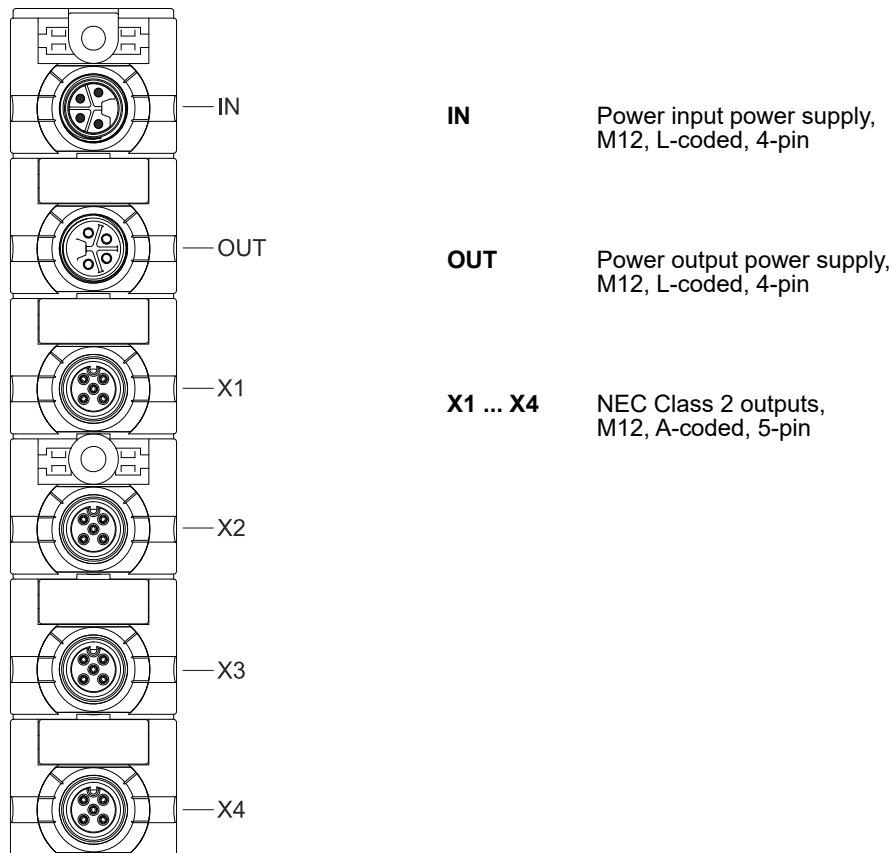

2 PIN assignment

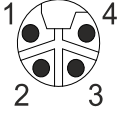
M12 male connector, L-coded, 4-pin – power input IN		
	Pin 1	24 V $\overline{\text{---}}$ US
	Pin 2	GND UA
	Pin 3	GND US
	Pin 4	24 V $\overline{\text{---}}$ UA (≤ 40 °C, see derating)

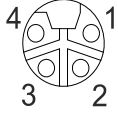
M12 female connector, L-coded, 4-pin – power output OUT		
	Pin 1	24 V $\overline{\text{---}}$ US
	Pin 2	GND UA
	Pin 3	GND US
	Pin 4	24 V $\overline{\text{---}}$ UA (≤ 40 °C, see derating)

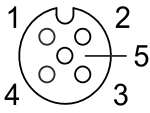
M12 female connector, A-coded, 5-pin – NEC outputs Class 2 X1 ... X4		
	Pin 1	24 V $\overline{\text{---}}$ NEC Class 2 24 V $\overline{\text{---}}$ (18 ... 30 V $\overline{\text{---}}$), 3,8 A (4 ...3 A)
	Pin 2	n.c.
	Pin 3	GND NEC Class 2 24 V $\overline{\text{---}}$ (18 ... 30 V $\overline{\text{---}}$), 3,8 A (4 ...3 A)
	Pin 4	n.c.
	Pin 5	n.c.

3 Electrical data

Power input IN supply		
Connection/male connector		M12, L-coded, 4-pin
Operating voltage US	Pin 1 (Pin 3)	24 V ---
Voltage range US	Pin 1 (Pin 3)	18 ... 30 V ---
Total current US	Pin 1 (Pin 3)	≤16 A
Operating voltage UA	Pin 4 (Pin 2)	24 V ---
Voltage range UA	Pin 4 (Pin 2)	18 ... 30 V ---
Total current UA	Pin 4 (Pin 2)	≤16 A (≤40 °C, see derating)
Current consumption	In idle mode, at operating voltage	35 mA
Reverse-polarity protection	For internal electronics only	No
Galvanic isolation		None
Connection cross-section	≤12 A >12 A	≥1,5 mm ² ≥2,5 mm ²
Cable length		≤30 m

Forwarding to power output OUT		
Connection/female connector		M12, L-coded, 4-pin
Operating voltage US	Pin 1 (Pin 3)	24 V ---
Voltage range US	Pin 1 (Pin 3)	18 ... 30 V ---
Total current US	Pin 1 (Pin 3)	≤16 A
Operating voltage UA	Pin 4 (Pin 2)	24 V ---
Voltage range UA	Pin 4 (Pin 2)	18 ... 30 V ---
Total current UA	Pin 4 (Pin 2)	≤16 A (≤40 °C, see derating)
Connection cross-section	≤12 A >12 A	≥1,5 mm ² ≥2,5 mm ²
Cable length		≤30 m

NEC Class 2 outputs X1 ... X4		
Connection/female connector		M12, A-coded, 5-pin
Disconnecting characteristics accuracy	Current	0 ... 9 %
Switching elements		Static switch
Module initialization time		10 ms
Parallel connection		Not possible
Nominal output voltage		24 V ---
Output voltage range		18 ... 30 V ---
Switch-on capacitance		10 mF
Tripping current	Full load Pin 1 (Pin 3)	3 ... 4 A (+9 %)
Connection cross-section		≥0,3 mm ²
Cable length		≤30 m

Power balance		
Voltage drop	per channel, at 50 % load	0.08 V
Efficiency	at 50 % load	99.7 %



CAUTION!

Temperatures exceeding 60 °C.

Minor injuries caused by touching the surface and damage to devices.

- ➔ Wear thermally suitable gloves.
- ➔ Use thermally suitable connecting cables only.



WARNING!

Risk of fire due to short circuit.

Supply lines and/or modules damaged by short circuit may overheat and cause fires.

- ➔ Provide intelligent current monitoring or fuse. The fuse must be designed for ≤ 16 A

Circuit diagram

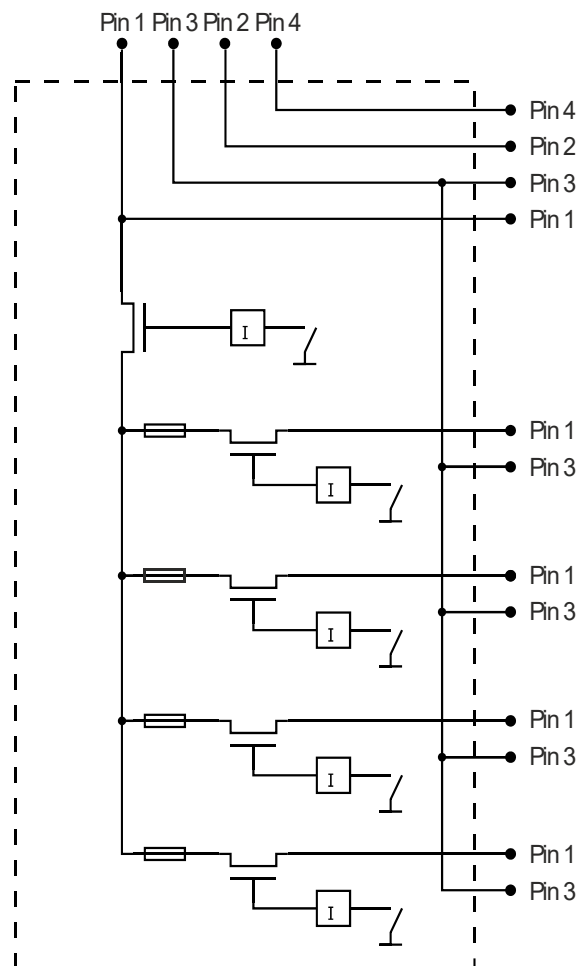

Derating actuator/sensor supply total current

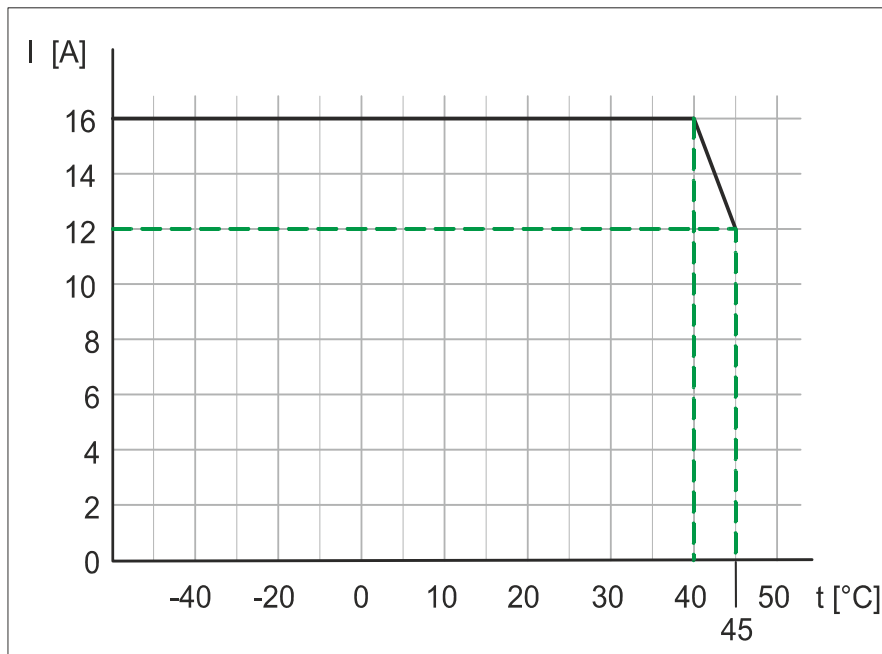

Fig. 3-1: Total current power output OUT pin 4 (pin 2)

4 Environmental characteristics

Climatic		
Operating temperature		-25 °C ... +45 °C
Storage temperature	For commissioning provide acclimatization	-25 °C ... +70 °C
Transport temperature	For commissioning provide acclimatization	-25 °C ... +70 °C
Relative humidity	No condensation	≤95 %
Installation height	Above sea level	≤3000 m
Mechanical		
Vibration test	EN 60068 Parts 2-6	Vibration amplitude 5 ... 500 Hz; 15 g 0.075 mm; XYZ axis
Shock test	IEC 60068 Part 2-27	50 g, duration 11 ms
Free fall	EN 61131-2	0.3 m
Electrical safety		
Degree of protection	EN 60529	IP65/IP67
Protection class	SELV or PELV power supply must be used	III
Degree of pollution		3
Emitted EMC interference		
Electromagnetic compatibility	IEC 61000-6-3	Residential, commercial, and light industrial environments.
EMC immunity		
Electromagnetic compatibility	IEC 61000-6-2	Industrial environments

5 Protection

Device protection		
Overvoltage protection	Power input IN supply	Suppressor diode 36 V
Overvoltage protection device supply	Must be provided by a power supply unit	Yes
Reverse-polarity protection	Available for internal electronics only	No
Short-circuit protection, sensor supply		Short circuit-proof
Overload protection	NEC outputs Class 2 X1 ... X4	See disconnecting characteristics / tripping current
Internal fuse	NEC outputs Class 2 X1 ... X4	F-S 2.7x6.1 4 A T

5.1 Disconnecting characteristics / tripping current

I_N = nominal current | The disconnection time in case of short circuit is approx. 5 ms

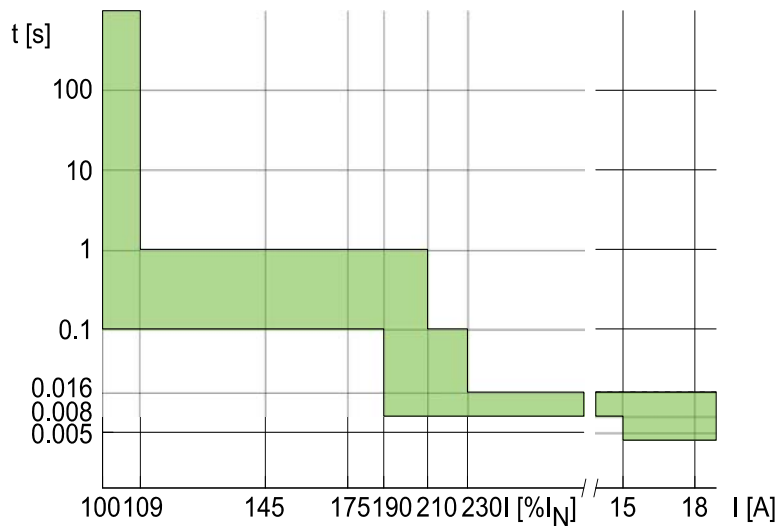

Fig. 5-1: Disconnecting characteristics

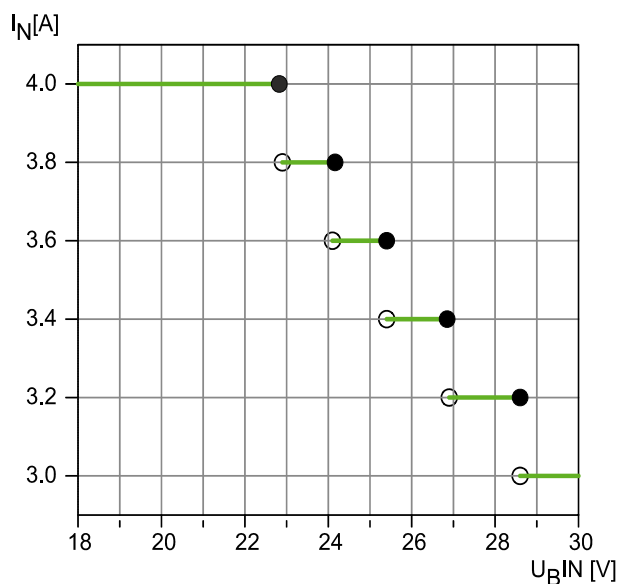

Fig. 5-2: Tripping current

6 Mechanical data

Material data		
Housing material		Plastic PBT/PC
Flame resistance	IEC 60695-2-1	Low flammability
Assembly data		
Weight	Net	158 g
Dimensions	L x W x H	151 x 30 x 34.8 mm

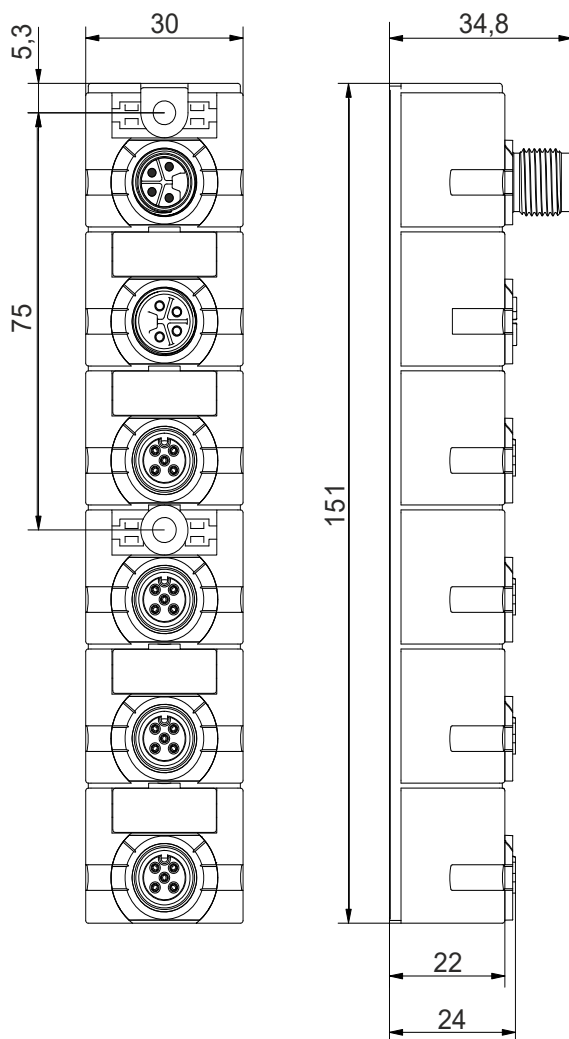

Fig. 6-1: Dimensions mm



7 Product reliability

MTTF	SN 29500 (at 40 °C and rated data)	139 years
------	------------------------------------	-----------







8 Operation

8.1 LED indication

LED indication Input

Indication	State	Description
 Green	Permanently on	Supply voltage is present
 Off		No voltage

LED indication Outputs X1 ... X4

Indication	State	Description
 Green	Permanently on	Error-free operation
 Green	Flashing at 1 Hz	Channel in the limit range, ≥90 % of the tripping current
 Red	Permanently on	Supply voltage <11 V channel switched off
 Red	Flashing at 1 Hz	Overload, short-circuit channel switched off
 Red	Flashing at 5 Hz	Defective device
 Off		No voltage



NOTE

All channels are in their conductive state when the operating voltage is applied (LEDs light up green)
Deactivated channels can be brought back to their conductive state by lowering the operating voltage to **≤10 V**.











9 Conformity, Approvals

Conformity, approvals		
Product standard	EN 61000-6-2 EN 61000-6-3	
CE	2014/30/EU 2011/65/EU	
UKCA	Electromagnetic Compatibility Regulations 2016, The Restriction of the Use of Certain Hazardous Substances in Electrical and Electronic Equip- ment Regulations 2012	
RoHS	2011/65/EU & 2015/863	Exception
REACH	No. 1907/2006	SVHC List
WEEE	2012/19/EU	WEEE compliant
China RoHS	GB/T 26572	25 EPUP
cUL	CSA C22.2 No. 61010-1-12 CSA C22.2 No. 61010-2-201	E201820
cULus	Amendment Class 2 UL1310/CSA C22.2 No. 223	E201820
ULus	UL 61010-1 UL 61010-2-201	E201820
ULus	Amendment Class 2 UL2367	E201820

Hazardous substance (有害物質)							
	Part Name 零件名稱	Lead	Mercury	Cadmium	Hexavalent	Polybrominated	Polybrominated
		(Pb) 鉛	(Hg) 汞	(Cd) 鎘	Chromium (Cr (VI)) 六价铬	biphenyls (PBB) 多溴联苯	diphenyl ethers (PBDE) 多溴联苯醚
	Component part PCB ^{1 2} 组件部分 印刷电路板	X	0	0	0	0	0
	Connection Terminal / Screws / Housing ³ 接线端子 / 拧 / 外壳	X	0	0	0	0	0
O : Indicates that the content of the harmful substance in all homogeneous materials of the component part is below the limit defined in GB/T 26572. O : 表明該有害物質在組成部分的所有均質材料的含量低於按GB/ T26572定義的限制。 X: Indicates that the content of the harmful substance in at least one homogeneous material of the component part exceeds the limit defined in GB/T 26572. X: 表示該有害物質在組成部分中的至少一個均質材料的含量超過按GB / T26572定義的限制。							

- 1 EU RoHS Directive 2011/65/EU, Annex III: Exemption 7(a) Lead in high melting temperature type solders (i.e., lead-based alloys containing 85 % by weight or more lead)
- 2 EU RoHS Directive 2011/65/EU, Annex III: Exemption 7(c)-I Electrical and electronic components containing lead in a glass or ceramic other than dielectric ceramic in capacitors, e.g., piezoelectronic devices, or in a glass or ceramic matrix compound.
- 3 EU RoHS Directive 2011/65/EU, Annex III: Exemption 6(c) Copper alloy containing up to 4 % lead by weight.

10 Symbol Description

Symbol	Function / description
	General mandatory sign: Follow the mandatory action specified by the supplementary sign
	Read instruction manual before installation
	Electrotechnical expertise is required
	Mechanical expertise is required
	Do not disconnect under load
	For indoor use only
	Observe country-specific waste disposal regulations
	Maximum installation height
	Warning: Hot surface
	General warning sign: Refer to the additional sign for the specific hazard
	Warning: Electricity